

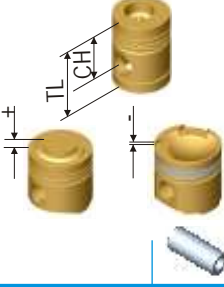













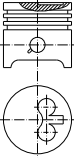
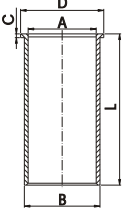
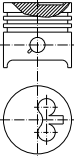
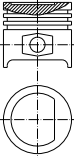

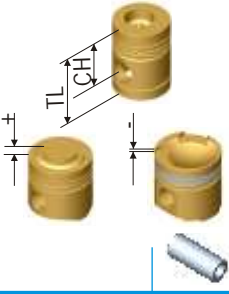

|    | No | Ø<br>mm |                               |  | Type |  |  |  |   |
|--|----|---------|--|---|------|--|---|---|--|
| <b>PEUGEOT</b>   |    |         |  |   |      |  |   |   |  |
| <b>Diesel Motor:</b><br>XUD 7 161 A, 1769 cm <sup>3</sup> ,<br>44 KW (60 PS),<br>23:1<br>Strok:88 mm<br><b>Vehicle:</b><br>205 GRD XLD/XRD/XAD 309<br>1983...  | 4  | 80.00   | 46.80<br>-2.00<br>84.50<br>   | 25.00<br>x<br>69.80   |      | 2.00 R CRP<br>2.00 T P<br>3.00 C CRP   | 80.00<br>80.50<br>80.80   | P 54010 00<br>P 54010 10<br>P 54010 20  | <br>A=80.00<br>B=83.00<br>L=154.00<br>D=86.00<br>C=4.50 |
| <b>Diesel Motor:</b><br>XUD 9, XUD 9 A,<br>1905 cm <sup>3</sup> , 23.5:1<br>205 D/GLD/GRD/XLD/<br>XRD (USA) 581 M 40,<br>305 GLD Seri II<br>581 E 40,<br>305 GLD BREAK Seri II<br>581 M 48,<br>305 SRD Seri II<br>581 U 40 305 BREAK<br>581 440 305 BREAK/Servis<br>10 SD 92, 309 XAD<br>10 CD 92, 309 XLD/XRD<br>10 AD 92, 309 GLD/GRD<br>309 SRD<br>15 BD 92, 405 GLD/GRD<br>15 EB 92, 405 GLD BREAK<br>15 ED 92,<br>405 GRD BREAK J5 D<br>1988... | 4  | 83.00   | 46.80<br>-2.20<br>84.30<br> | 25.00<br>x<br>72.00   |      | 2.00 R CRP<br>2.00 T P<br>3.00 C CRP   | 83.00<br>83.50  | P 54020 00<br>P 54020 10  |  |
| <b>Diesel Motor:</b><br>XU 5 S-XU 5 CP-XUB.2C<br>XU 5 B.1A/B.1E 171 A/B/C/D<br>1580 cm <sup>3</sup> , 9.5:1<br>BX 15 RE/TGE/TRE/<br>XB Seri EE/FA/FB<br>1987...<br>BX 16 TGS/BREAK EVASION<br>/ATHENA/LEADER<br>XB Seri XB/AA-XE/T-XB/T<br>BX 16 RS/TG/TRS/TS/<br>XB Seri XB-XE/XK/KS<br>1982...<br>Peugeot 205 Automatic<br>305 GT/Automatic,<br>305 SR/GR<br>1986...   | 4  | 83.00   | 37.50<br>-2.10<br>67.50<br> | 22.00<br>x<br>66.00   |      | 1.75<br>1.75<br>4.00   | 83.00   | P 54022 00  |  |

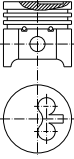
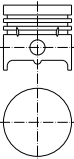
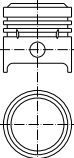
|    | No | Ø<br>mm |                                  | Type                |  |  |  |  |  |
|--|----|---------|---|---------------------|--|---|---|---|--|
| <b>PEUGEOT</b>   |    |         |   |                     |  |   |   |   |  |
| <b>Diesel Motor:</b><br><b>Vehicle:</b><br>TATA 4 DL   | 4  | 83.00   | 46.85<br>-2.20<br>84.25<br><br>  | 25.00<br>x<br>70.40 | ST<br><br>2.00 R CRP<br>2.00 T P<br>3.00 C CRP                                     | 83.00<br>83.50<br>84.00   | P 54024 00<br>P 54024 10<br>P 54024 20  |   |  |
| <b>Benzin Motor:</b><br>XM 7, XM 7 P, XM 7 T,<br>1796 cm <sup>3</sup> ,<br>7.5:1<br><b>Vehicle:</b><br>504 L/GR/SR/BREAK/<br>UTILITAIRE<br>COMMERCIALE E 01/03<br>505 GR-505 A/D/F/01/71/77-<br>A 03/AF 73<br>J 5 1000 FOURGON<br>COMBI A 11/C 11- E 01<br>J 7 1800 F/PZ/PW/PX/PY<br>E 01/C 11/PZ 20   | 4  | 84.00   | 38.00<br>71.30<br><br>         | 23.00<br>x<br>70.00 | 1.50 R CRP<br>2.00 TN P<br>4.00 C CRP  | 84.00   | P 54030 00  |   |  |
| <b>Benzin Motor:</b><br>XN 1, XN 1 P, XN 1T, XN 2<br>1971 cm <sup>3</sup> , 8.35:1<br><b>Benzin Motor:</b><br>XN 1(106)<br>504 GL/GR<br>504 F 11/H 11/A 11/A13/<br>D11/F11<br>505 GL/GR/SR<br>551 A 01/A 11/D 17/F17<br>J5 1300 FOURGON<br>J9 1800 FOURGON<br>J9 1900<br><b>Benzin Motor :</b><br>XN 2 (107) 504 Injection<br>504 TI/CABRIOLET/COUPE/<br>Injection<br>A 12/A 14/B14/C12/ C14 | 4  | 88.00   | 38.25<br>0.65<br>71.85<br><br> | 23.00<br>x<br>74.10 | 1.50 R CRP<br>2.00 TN P<br>4.00 C CRP  | 88.00<br>88.50  | P 54040 00<br>P 54040 10  |   |  |

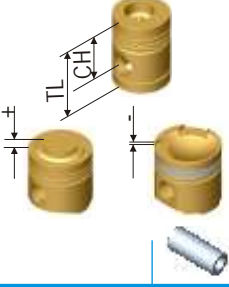
|    | No | Ø<br>mm |  | Type                |  |  |  |    |  |
|--|----|---------|---|---------------------|--|---|---|---|--|
| <b>PEUGEOT</b>   |    |         |   |                     |  |   |   |   |  |
| <b>Benzin Motor :</b><br>1971 cm <sup>3</sup> ,<br>8.35:1<br>MOT XN1 CARBU<br>MOT XN1 PCARBU<br>MOT XN1T CARBU<br><b>Vehicle:</b><br>504 GL/BREAK GL/GR<br>504 F11/H11<br>505 GL/GR/SR/BREAK<br>J 5 1300 FOURGON/COMBI<br>MOT XN 2 INJECTION<br>504 INJECTION<br>504 TI/CABRIOLET/COUPE                                  | 4  | 88.00   | 37.90<br>1.35<br>72.20  | 23.00<br>x<br>74.10 | 1.50 R CRP<br>2.00 TN P<br>4.00 C CRP  | 88.00   | P 54042 00  |    |  |
| <b>Diesel Motor:</b><br>XD/XDP/TMD 4.88,<br>1948 cm <sup>3</sup> ,<br>36-46 KW (49-63 PS),<br>21-21.8:1<br><b>Vehicle:</b><br>404 D, U 6D, U 8 D, U 10 D,<br>504 D, J 7 D,<br>Motor No: 4.630.386<br><b>Diesel Motor:</b><br>XDP 6.88, 2919 cm <sup>3</sup><br>61 KW (83 PS), 21:1<br>Motor No: 4.630.386<br>1963...1977 | 6  | 88.00   | 58.70<br>-2.00<br>95.35   | 28.00<br>x<br>72.00 | 2.00 R CR<br>2.00 R<br>2.00 N<br>4.50 C  | 88.00   | P 54044 00  | <br>A=80.00<br>B=96.00<br>L=173.00<br>D=106.30<br>C=7.00 |  |
| <b>Disel Motor:</b><br>XDP 4.90, 2112 cm <sup>3</sup> ,<br>43.5-45.5-48-55 KW<br>(59-62-65-75 PS)<br>21-21.5-22.1:1<br><b>Vehicle:</b><br>504 D, J 7 D, J 9 D,<br>1967...1978<br><b>Diesel Motor:</b><br>XDP 6.90, 3168 cm <sup>3</sup><br>78 KW (106 PS), 22.2:1<br>1967...1982   | 6  | 90.00   | 57.20<br>-2.00<br>96.70   | 28.00<br>x<br>77.00 | 2.00 R CR<br>2.00 R<br>2.00 R<br>4.50 C  | 90.00   | P 54050 00  | <br>A=90.00<br>B=96.00<br>L=173.00<br>D=106.30<br>C=7.00 |  |

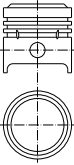
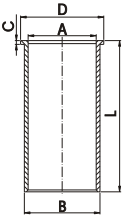
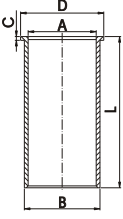
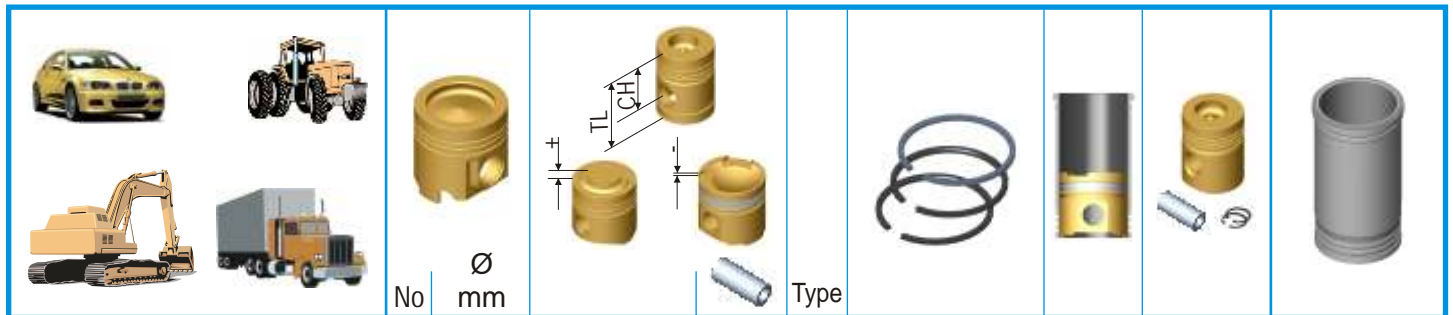

## PEUGEOT

### Diesel Motor:

U 25/651, U 25/ 661 ,  
2499 cm<sup>3</sup>,  
54 KW (75PS), 22.25:1

### Vehicle:

J 5 D, Fourgon,  
Combi 1000/1300

10/1983...

4

93.00

52.80

-5.40

-7.40

95.00

30.00

x

78.00

2.50 R CR

2.00 R

4.00 C

93.00

P 54060 00

93.25

P 54060 10

93.50

P 54060 20

93.75

P 54060 30

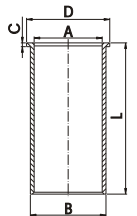
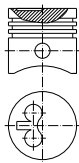

A=93.00  
B=97.50  
L=163.00  
D=99.00  
C=5.00

### Diesel Motor:

XD 2/2 P, XD 94, 2304 cm<sup>3</sup>,  
46.5-53 KW (63.5-72 PS),  
22.2:1

### Vehicle:

504 D/GLD/Break D,  
505 GRD/SRD,  
504 Utilitaire  
J 7 PZ 6O 1800,  
J9 1800

1976...1981

4

94.00

57.42

-2.00

99.92

28.00

x

81.00

2.00 R CR

2.00 T

4.00 C CR

94.00

P 54070 00

94.40

P 54070 10

94.60

P 54070 20

95.00

P 54070 30

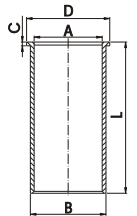
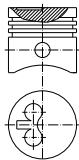

A=94.00  
B=97.00  
L=170.60  
D=99.50  
C=3.90

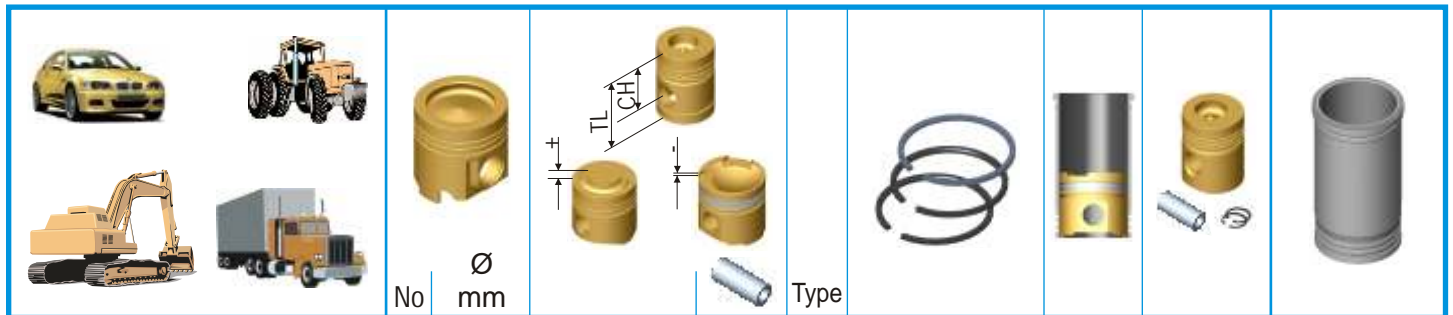

## PEUGEOT

### Disel Motor:

XD2/2P, XD94, 2304 cm<sup>3</sup>,  
46.5-53 KW (63.5-72 PS),  
22.2:1

### Vehicle:

504 D/GLD/Break D,  
505 GRD/ SRD,  
504 Utilitaire/Pick-up 1800,  
J7 PZ 60 1800,  
J9 Fourgon/Pick-up 1800,  
1982...1984

4 94.00

57.42  
-2.00  
99.92

30.00  
x  
78.00

2.00 R CR  
2.00 R  
4.00 C CR

|       |            |
|-------|------------|
| 94.00 | P 54072 00 |
| 94.40 | P 54072 10 |
| 94.60 | P 54072 20 |
| 95.00 | P 54072 30 |

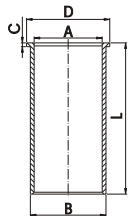
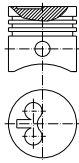

A=94.00  
B=97.00  
L=170.60  
D=99.50  
C=3.90

### Disel Motor:

XD3P, 2498cm<sup>3</sup>,  
51.5-56 KW (70-76 PS),  
23:1

### Vehicle:

505 D, J 9 D, 505 GLD/GRD  
1982...

4 94.00

53.92  
-1.80  
96.42

30.00  
x  
78.00

2.00 R CR  
2.00 T  
4.00 C CR

|       |            |
|-------|------------|
| 94.00 | P 54074 00 |
| 94.40 | P 54074 10 |
| 94.60 | P 54074 20 |
| 95.00 | P 54074 30 |

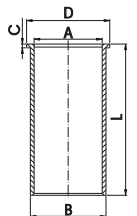
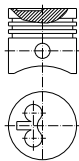

A=94.00  
B=97.00  
L=165.80  
D=99.50  
C=3.90