

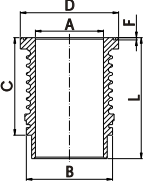

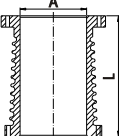

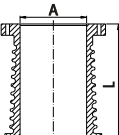

## ATLAS COPCO

<b>Compressor:</b> <b>Type: 1612-1872</b>	1	95.00	62.00 108.00	22.00 x 63.60	2.50 AT P 2.50 AT P 4.00 DS P 4.00 DS P	95.00	P 11010 00	L 11010 00  A=95.00 B=114.95 L=158.00 D=130.95 C=83.90 F=2.20
<b>Compressor:</b> <b>Type: KT4-K1 1588</b>	1	100.00	60.50 95.50	24.00 x 48.30	4.00 AT P 4.00 AT P 4.00 DS P 4.00 DS P	100.00	P 11012 00	L 11012 00  A=100.00 L=155.00
<b>Compressor:</b> <b>Type: KT6-K1 1589</b>	2	125.00	62.00 102.00	30.00 X 62.50	4.00 AT P 4.00 AT P 4.00 DS P 4.00 DS P	125.00	P 11014 00	L 11014 00  A=125.00 L=193.00

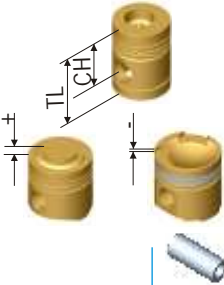
						
No	∅ mm	Type				

## ATLAS COPCO

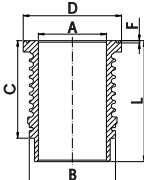
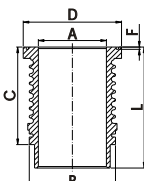
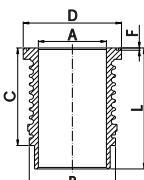
<b>Compressor:</b> <b>Type:</b> BT4 1404-1955	1	130.00	85.00 148.00	30.00 X 81.00	3.00 T P 3.00 T P 4.00 DS P 4.00 DS P	130.00	P 11016 00	L 11016 00  A=130.00 B=159.92 L=209.00 D=169.95 C=129.85 F=2.20
<b>Compressor:</b> <b>Type:</b> 1612-1871	1	155.00	64.00 110.00	22.00 X 64.00	4.00 4.00 4.00	155.00	P 11018 00	L 11018 00  A=155.00 B=174.93 L=209.00 D=184.95 C=83.95 F=2.20
<b>Compressor:</b> <b>Type:</b> 1614-0305	1	220.00	68.00 151.00	30.00 X 81.00	4.00 4.00 4.00 4.00	220.00	P 11020 00	L 11020 00  A=220.00 B=249.90 L=209.00 D=259.95 C=130.35 F=2.20